

TCA QUADRANT
AIRBUS EDITION

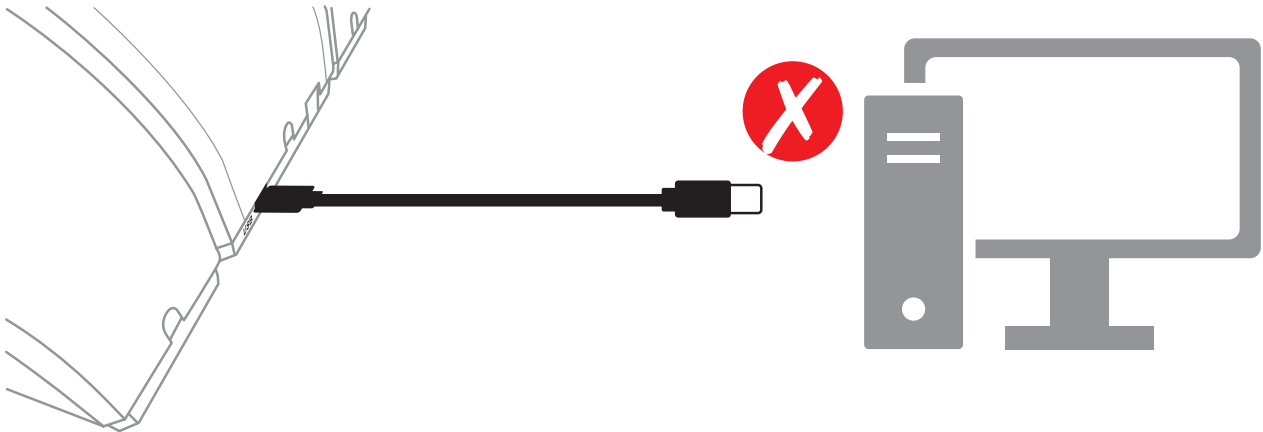

TCA QUADRANT ADD-ON
AIRBUS EDITION

I



II

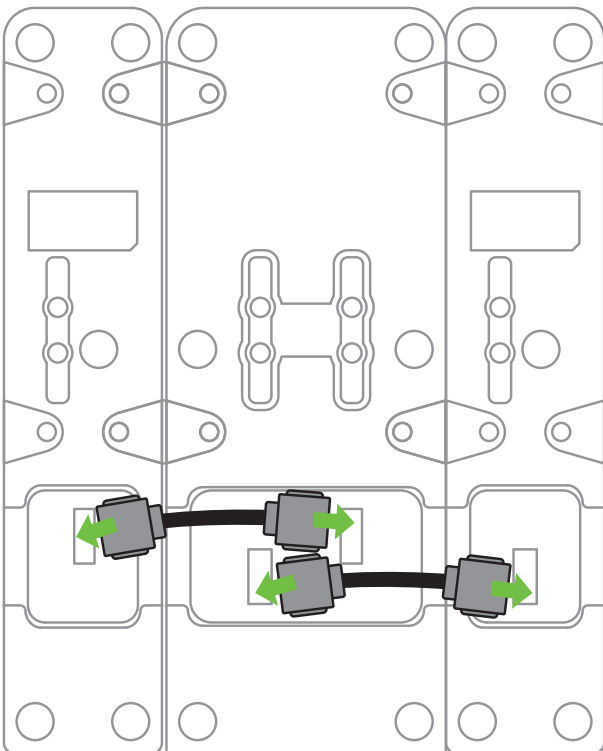

A

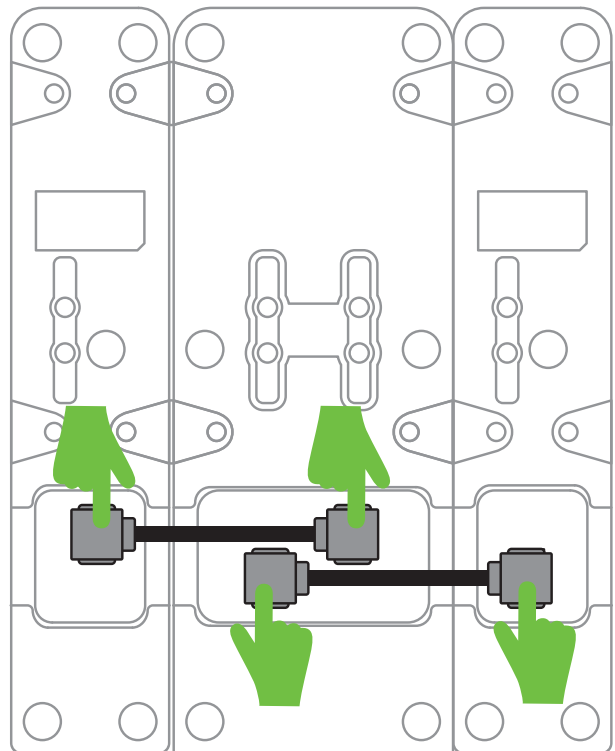

B

III

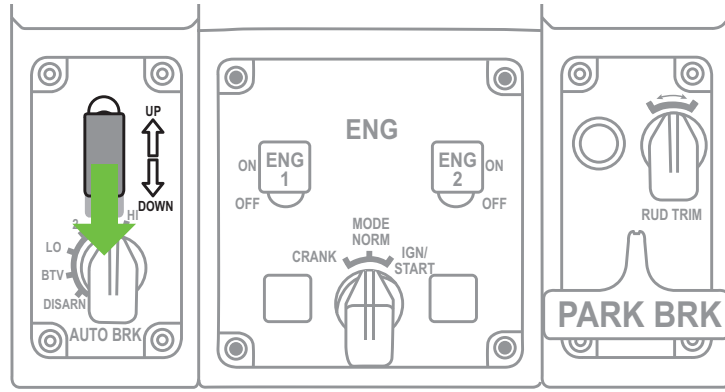

IV

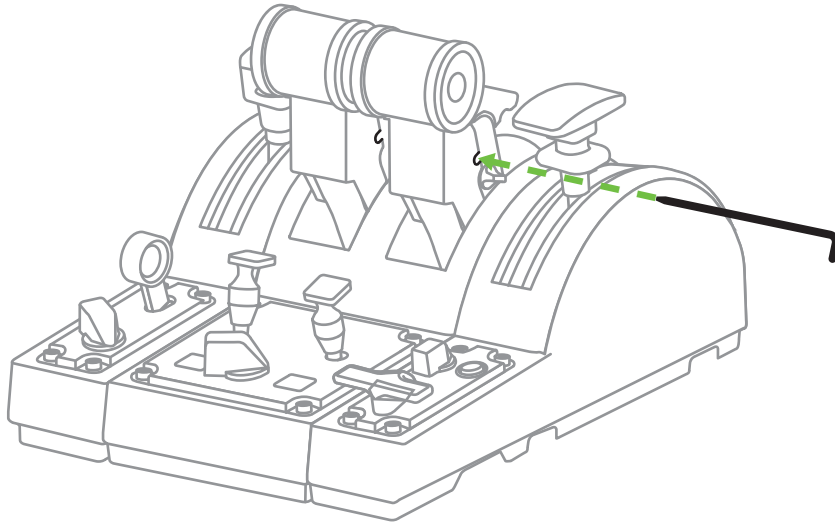

V

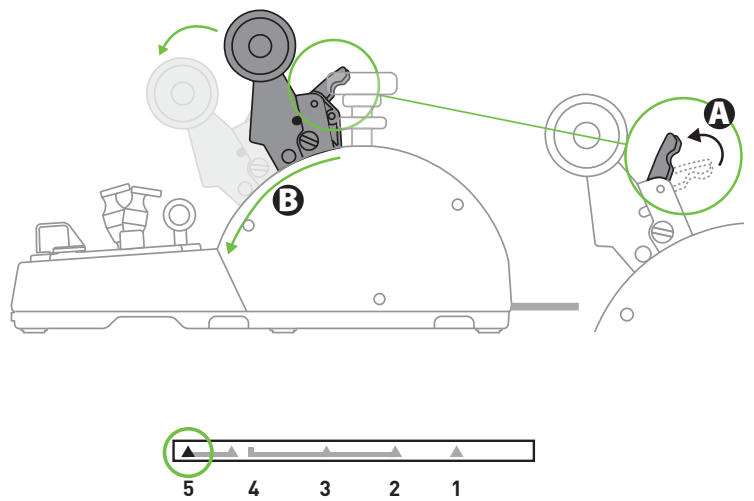
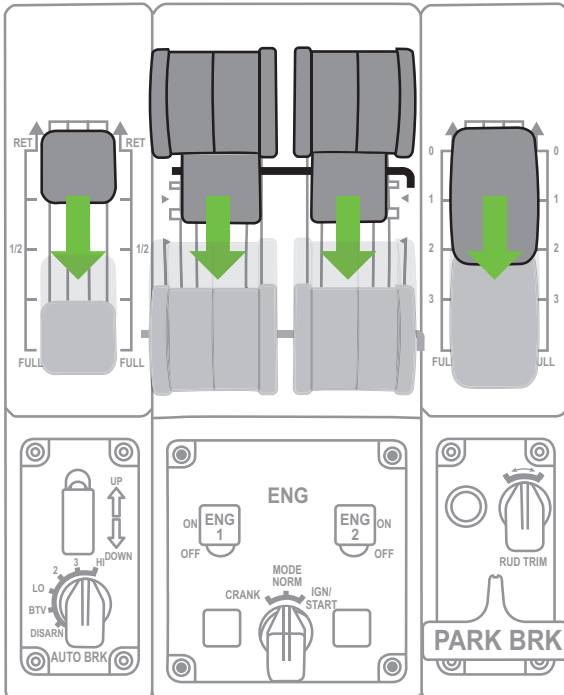

A

B

VI

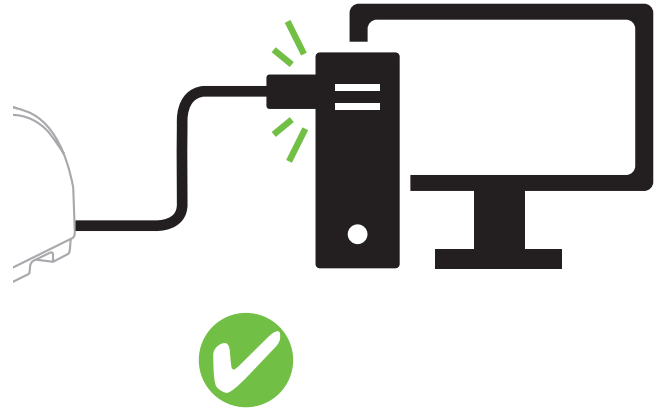
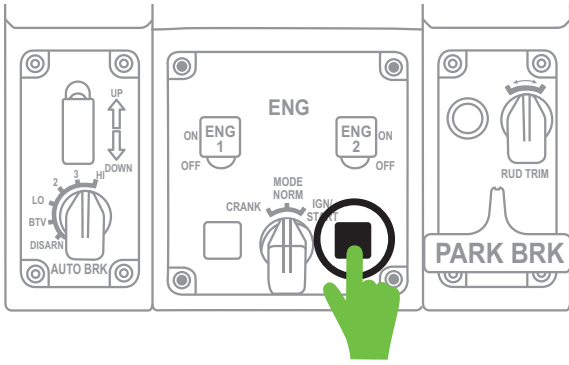

VII

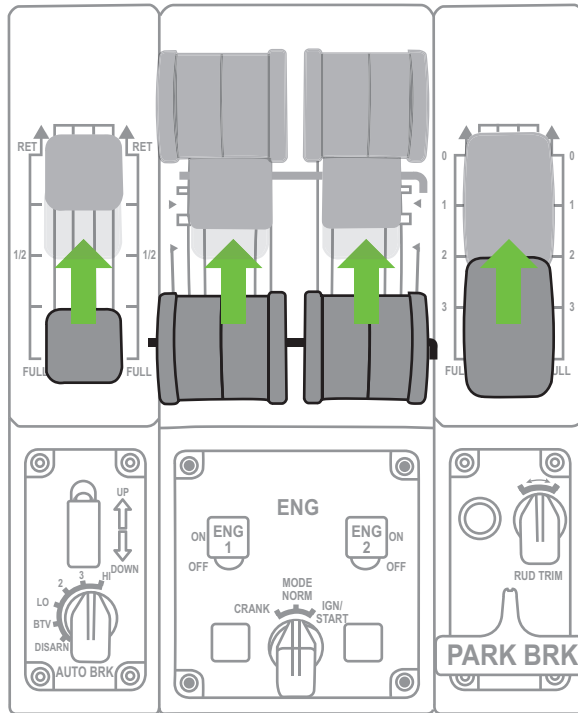

VIII

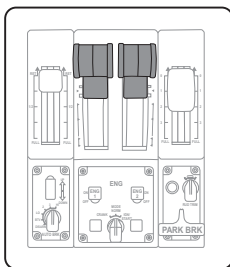

TO/GA

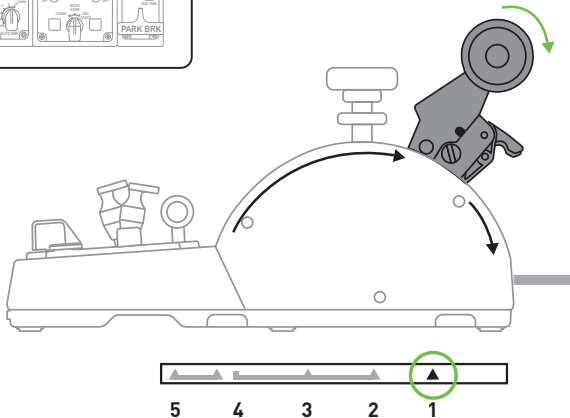

A

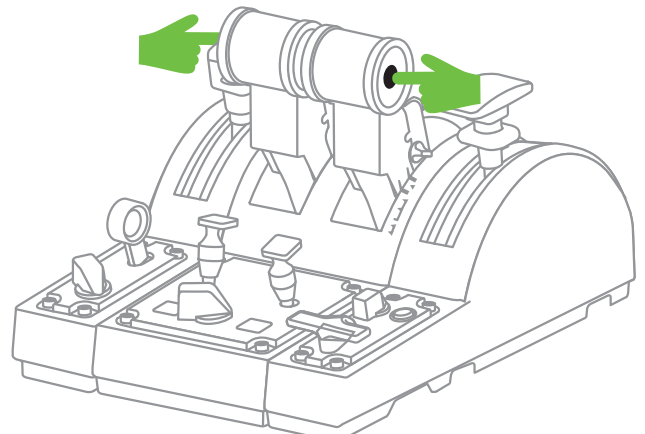

B

IX

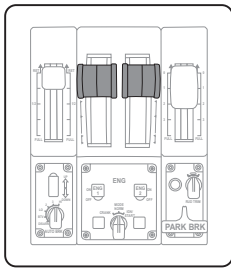

FLEX

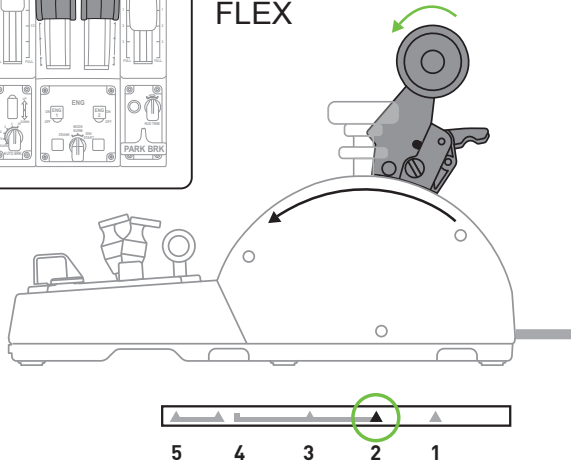

A

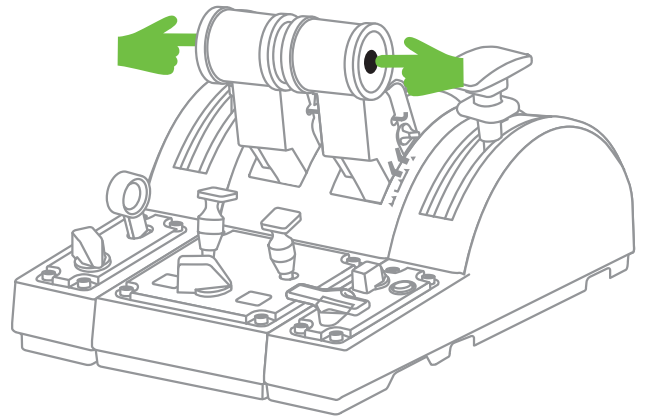

B

X

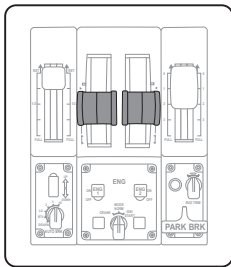

CLB

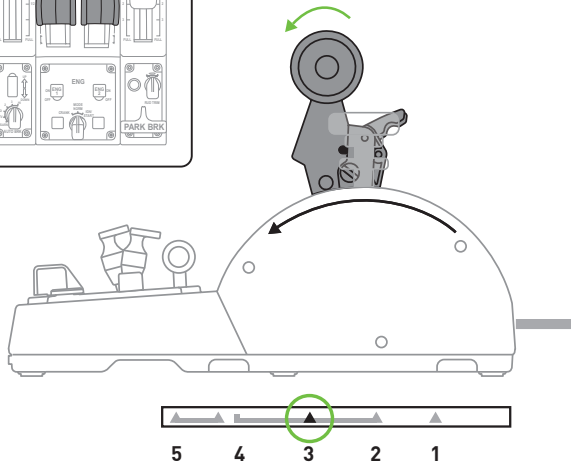

A

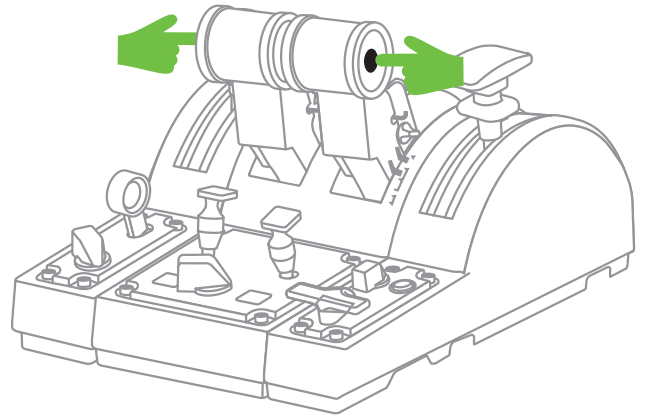

B

XI

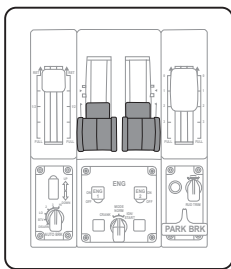

IDLE

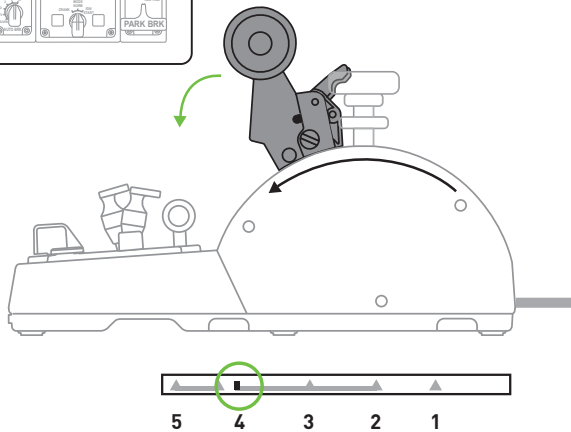

A

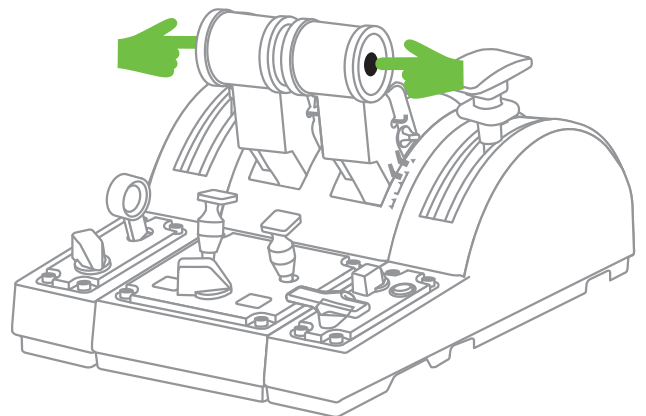

B

XII

RET



1/2

FULL

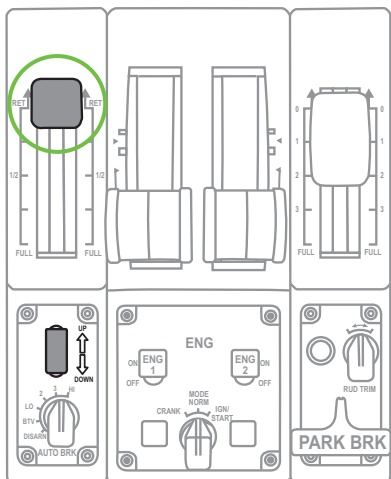

A

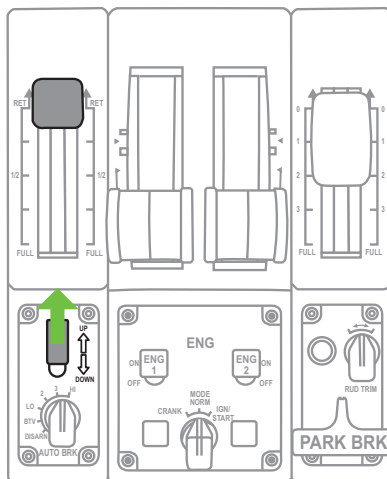

B

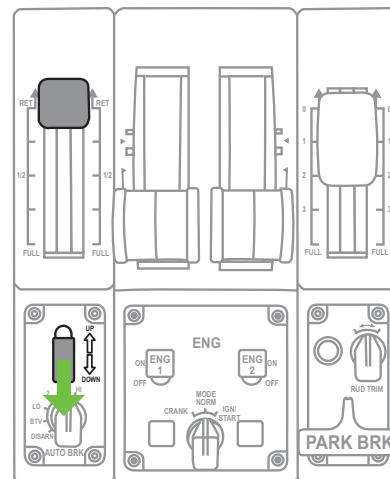

C

XIII

1/4

RET



1/2

FULL

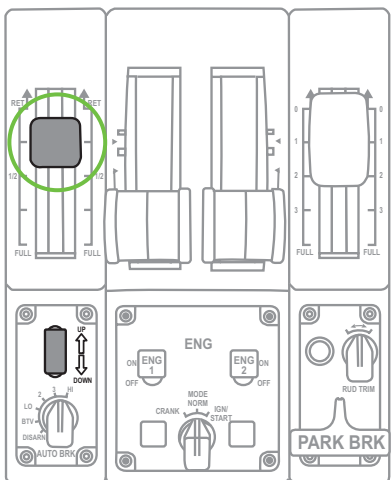

A

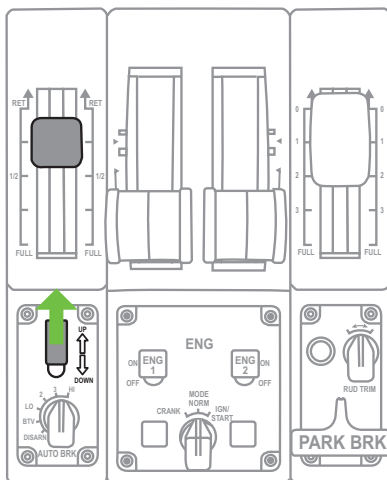

B

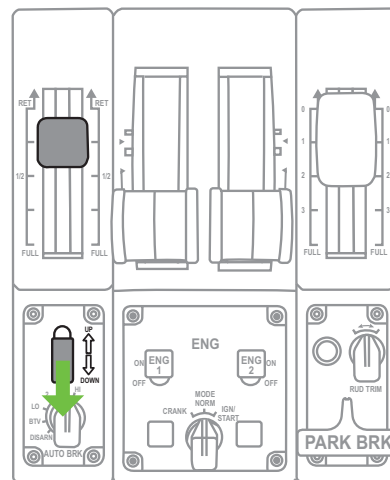

C

XIV

1/2

RET



FULL

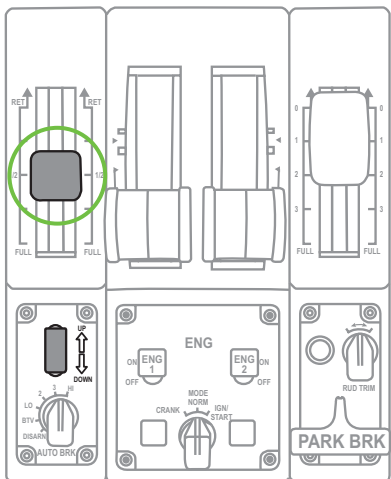

A

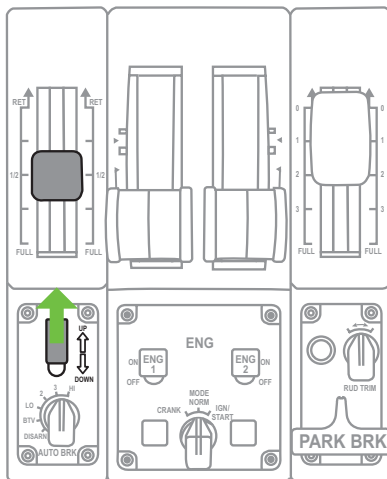

B

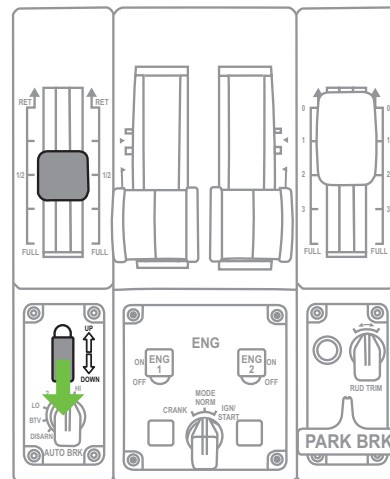

C

XV

3/4

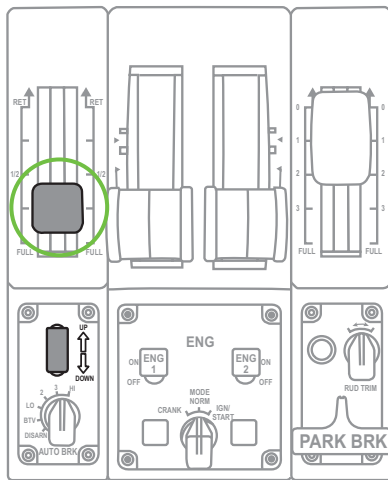

A

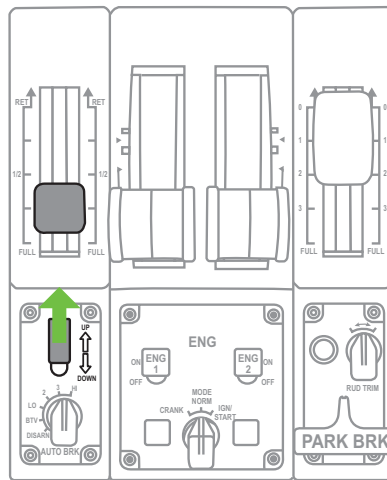

B

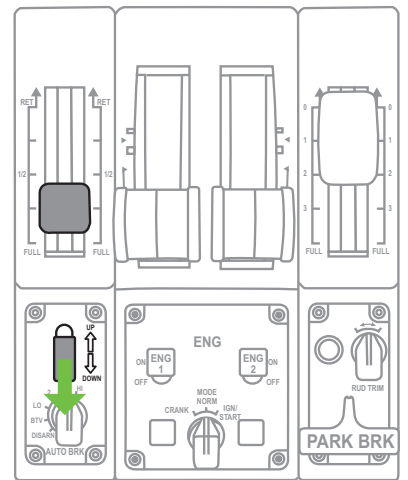

C

XVI

FULL

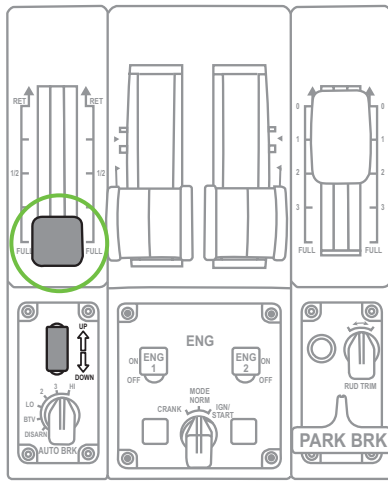

A

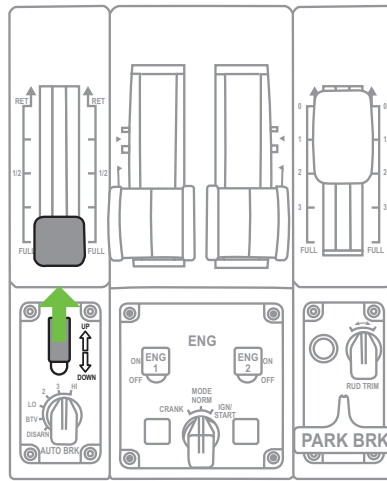

B

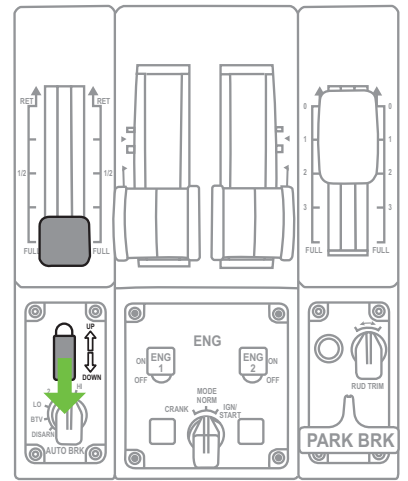

C

XVII

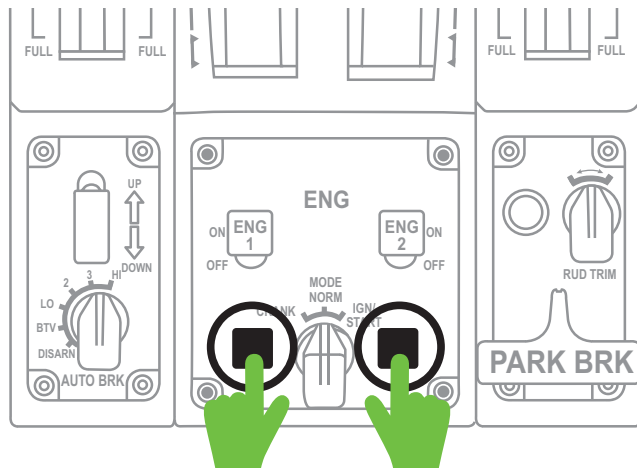

XVIII

